

EDGARD VARÈSE

IONISATION

for

Percussion Ensemble

of

13 Players

Full Score

Duration: 6½ minutes

COLFRANC MUSIC PUBLISHING CORPORATION
NEW YORK

General Agent: **e.c. kerby ltd.** 198 DAVENPORT ROAD TORONTO 5, ONTARIO, CANADA (416) 922 9934

Instruments

1. *A)* Grande Cymbale Chinoise (Crash Cymbal)
Grosse Caisse, très grave (Bass Drum, very deep)
Cencerro (muffled) *F)*
Tam-tam clair (high Tam-tam)
2. *B)* Gong
Tam-tam clair (high Tam-tam)
Tam-tam grave (low Tam-tam)
Cencerro (muffled) *F)*
3. 2 Bongos (high and low)
Caisse roulante (Side-drum) *C)*
2 Grosse Caisse à plat, moyenne et grave (2 Bass Drums laid flat, medium and large size)
4. Tambour Militaire *C)*
Caisse roulante (Side-drum) *C)*
5. Sirène claire (Siren, high) *D)*
Tambour à corde (String-drum or Lion's Roar)
6. Sirène grave (Siren, low) *D)*
Fouet (Slapstick)
Güiro
7. 3 Blocs chinois, clair, moyen et grave (3 Wood Blocks, high, middle and low register)
Claves
Triangle
8. Caisse claire, détimbrée (Snare-drum, with snares relaxed) *C)*
2 Maracas, claire et grave (2 Maracas, high and low)
9. Tarole *C) E)*
Caisse claire (Snare-drum) *C)*
Cymbale suspendue (Suspended Cymbal)
10. Cymbales (Cymbals)
Grelots (Sleigh Bells)
Cloches (Tubular Chimes)

11. Güiro
Castagnettes (Castanets)
Glockenspiel à clavier, with resonators
12. Tambour de Basque (Tambourine)
2 Enclumes, la première plus aiguë (2 Anvils, the first higher)
Grand Tam-tam (very deep)
13. Fouet (Slapstick)
Triangle
Grelots (Sleigh Bells)
Piano G)

A) A mallet in each hand.

B) A mallet in each hand; use very elastic strokes; even in the *ff*, the combined weight of arm and mallet are sufficient; do not kill the tone.

C) Skin, felt, sponge or wooden sticks are to be used strictly as indicated.

The notation $\begin{array}{c} R \\ | \\ X \end{array}$ indicates rim shot.

D) Sirens: Sterling Type H (Part No. 73 PU. PB.) hand operated with thumb brake. If unobtainable, substitute with theremin instruments. Mouth sirens are to be strictly avoided.

E) Tarole: A flat military high pitched drum with snares.

F) Cencerro: A cow bell with handle and no clapper; it is struck with drum stick and muffled by inserting a piece of soft material in the bell.

G) The symbol  indicates all chromatic intervals between the

two notes and must be played simultaneously making use of the forearm. The chord is to be played without stiffness and without brutality.

• IONISATION •

Chart for disposition of Percussion Ensemble suggested by Morris Goldenberg,
Instructor of Percussion, Juilliard School of Music.

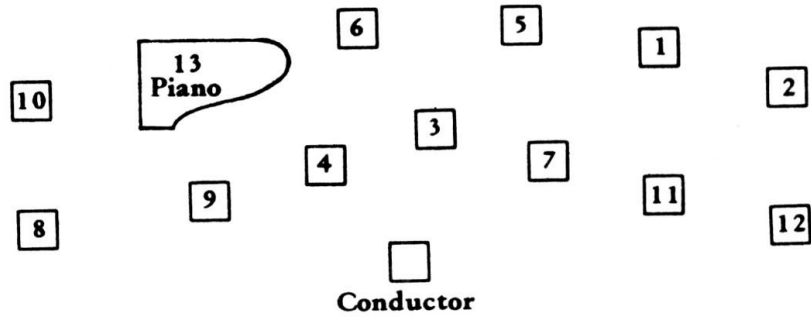

Charts for Individual Multiple Percussionists

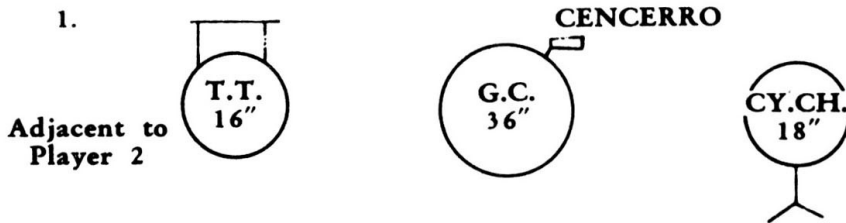

Footnote: Use soft Timpani mallet at outset. After ⑦ use Bell mallet in R.H. for Cowbell and Timpani mallet in L.H.



Footnote: See prototypes for Gong and Tam-Tam at end of section.

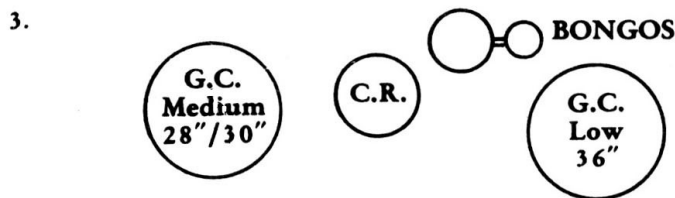

Footnote: Both Bass Drums are to be laid flat.



Footnote: The Caisse Roulante or Tenor Drum has no snares and is almost like a small Bass Drum. The Tambour Militaire, known also as either the Field or Parade Drum, has adjustable side snares.

5.

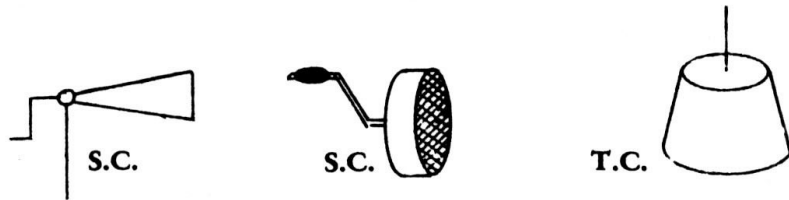

Footnote: See prototypes of High Siren and String Drum at end of Section.

6.

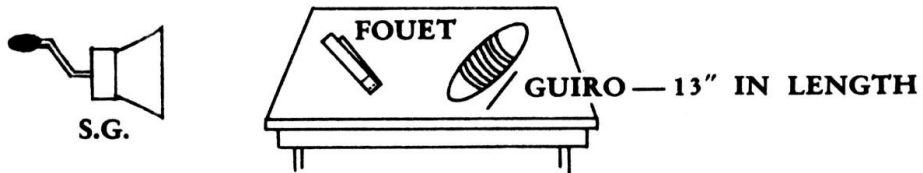

Footnote: See prototypes of Low Siren at end of section.

7.

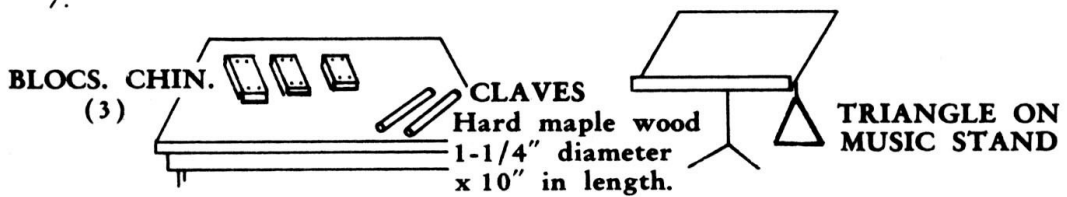

Footnote: Use Chinese Blocks (or the equivalent Wood Blocks) of 3 different pitches. Do *not* use Temple Blocks.

8.

NO DIAGRAM NECESSARY

9.

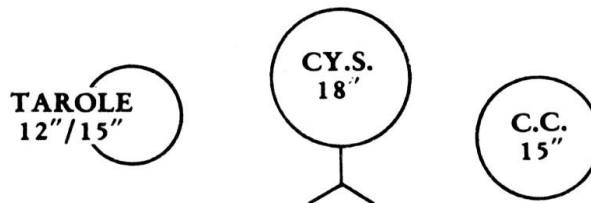

Footnote: The shell of the Tarole is extremely shallow.

10.

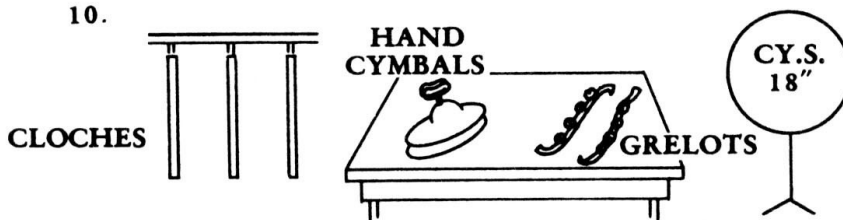

Footnote: Use Hand Cymbals wherever possible. The Suspended cymbal is only an alternative. (With wood sticks.)

11.

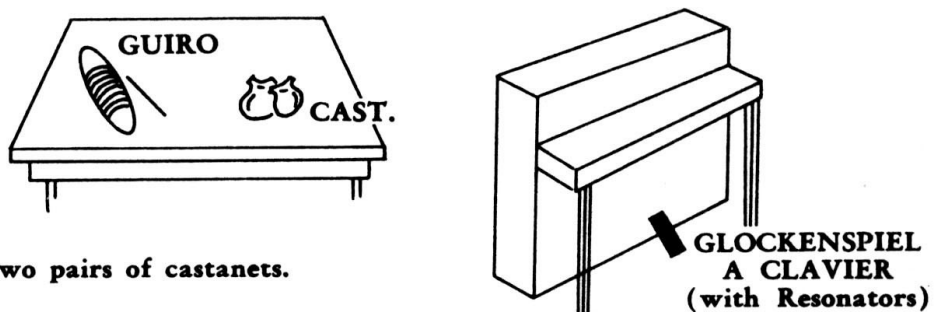

Footnote: Use two pairs of castanets.

12.

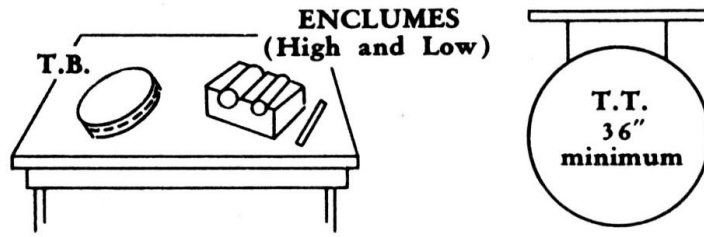

Footnote: See prototype of Anvils at end of page.

13.

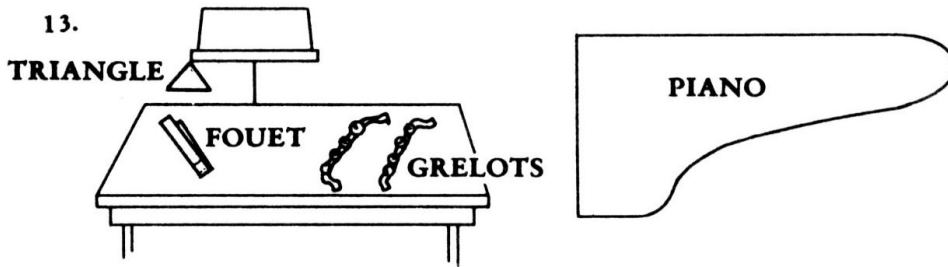

Prototypes

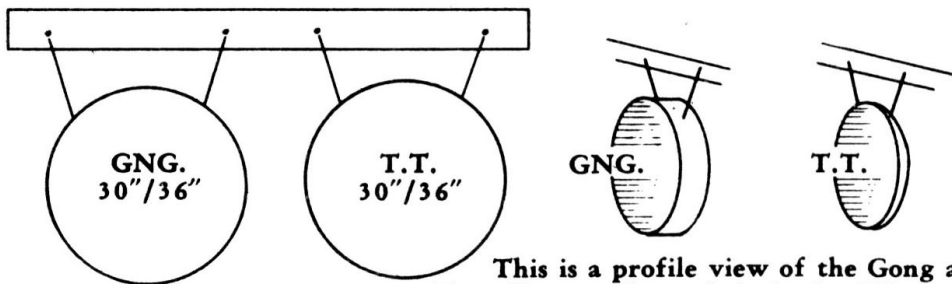

This is a profile view of the Gong and Tam-Tam to show their basic differences.

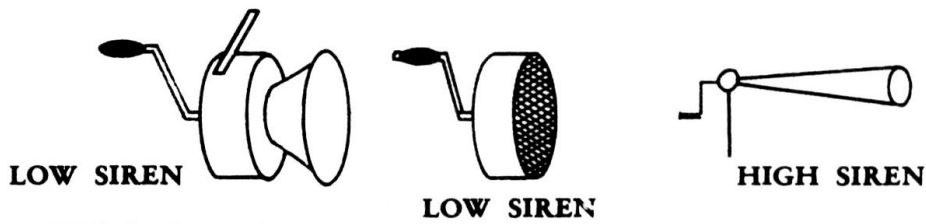

Footnote: With brake equipment.

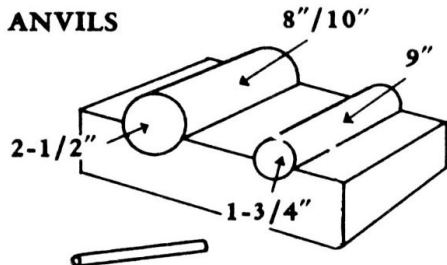

Footnote: Indentations in holder must be lined with soft felt to obtain maximum of resonance. To obtain resonance hit both tubes simultaneously with beater (small piece of tubing) held by the middle. Damping is obtained in the same fashion but keeping the contact with the two tubes.

STRING DRUM
(Lion's Roar)

